

# Aerial Transmission Plates & Plate Holders

Lordon's aerial transmission tower plates and holders provide utility companies with a solution for better transmission line tracking, inspections, and maintenance at a low cost. Our plates are highly visible from the air and on the ground and are available in 5 different finishes and 7 different sizes.

## **PLATE SIZES:**

TR Plate Sizes: 2", 2.5", 3", 4", 6", 8", 10"

## **PLATE HOLDER SIZES:**

- Aluminum:  
2", 2.5", 3", 4", 6"
- U.V. Polyethylene:  
2", 3", 4"
- Extruded Aluminum:  
2", 3", 4", 6", 8", 10"

## **3 ALUMINUM FINISHES:**

- Flat Printed Black/Yellow
- Embossed Black/Yellow
- Reflective Black/Yellow

## **2 POLYETHYLENE FINISHES:**

- Hot Stamped Black/Yellow or Yellow/Black
- Ultima 3D Engraved Black/Yellow UVHD Polyethylene

## **MOUNTING OPTIONS:**

- E-Z Bands in Aluminum & Stainless Steel
- E-Z Buckles in Aluminum, Anodized Aluminum & Stainless Steel
- Aluminum Nails

## **STORAGE BOX: TK-3S**

- **Dimensions:** 18" x 12" x 13" with movable compartments. Conveniently holds over 400 Plates, Plus nails.
- **Description:** Durable, all steel, welded construction; full length hinge with positive pull down locking catch and card holder.

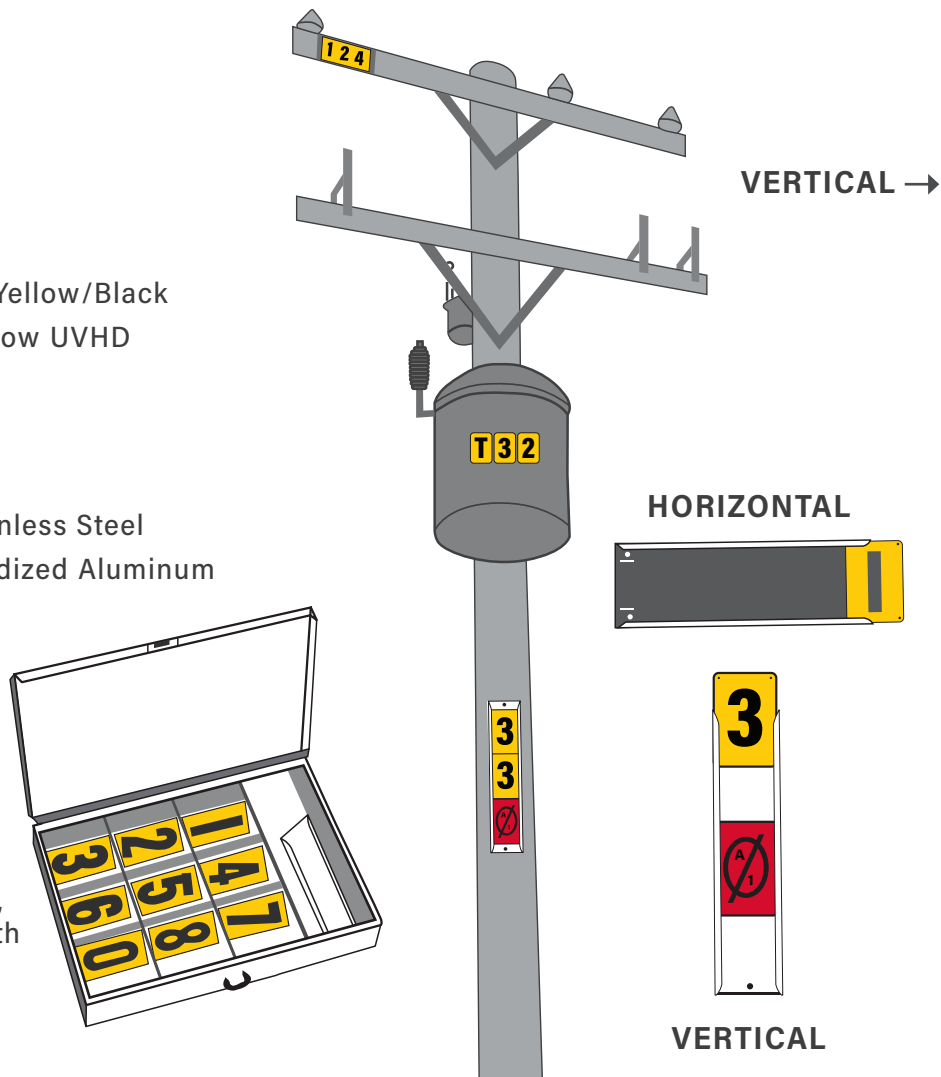
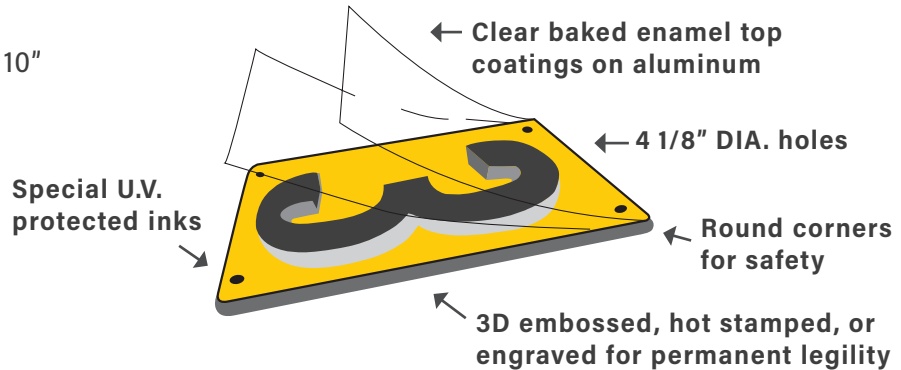

426 Sand Shore Road, Unit 3, Hackettstown, NJ 07840 • [csr@lordoninc.com](mailto:csr@lordoninc.com)

# Aerial Transmission Plates Finishes

## CHOOSE FROM 5 FINISHES

### U.V. SCREEN PRINTED ALUMINUM



Flat Printed Black on Yellow Aluminum



Embossed Black on Yellow Aluminum



Reflective Black on Yellow Aluminum

### U.V. DEEP STAMPED POLYETHYLENE



Hot Stamped Black on Yellow Polyethylene



Ultima Engraved 3-D Black on Yellow UV Polyethylene

## SPECIFICATIONS

### METAL TAGS:

Manufactured from .025 to .040 thick aluminum. Printed tags have a durable, clear baked enamel top coating with U.V. inhibitors which seal in image and add years of service to these quality tags.

### POLYETHYLENE TAGS:

Chemical and moisture resistant polyethylene treated to provide weatherability. Deep stamped or 3-D Engraved.

### REFLECTIVE TAGS:

Made of the finest 3M® Scotchlite or Avery materials and laminated to aluminum substrates. These tags are printed with U.V. enamels for maximum life and highly reflective qualities in all weather conditions.

# Plate Holders

Length of Holder is determined by Number of Tags

### ALUMINUM .024"

Available with holes or optional slots for banding. Vertical or horizontal styles in 2", 2.5", 3", 4" and 6" sizes.

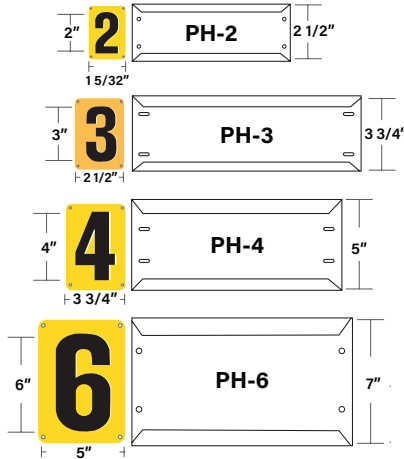

### EXTRUDED ALUMINUM .062"

Available with slots and holes for Vertical or Horizontal styles in: 2", 3", 4", 6" and 8" Horizontal and 10" Vertical.

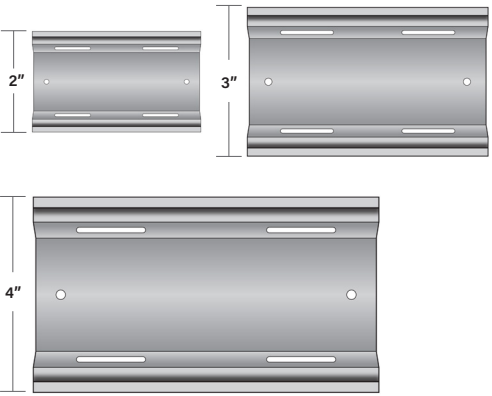

### U.V. POLYETHYLENE .050"

Vertical or Horizontal styles in 2", 3" and 4" Vertical.

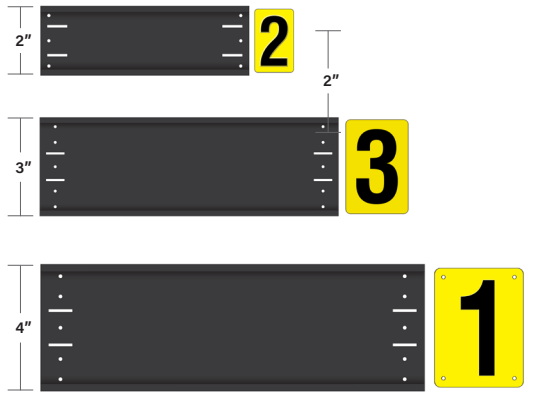

# Accessories

### E-Z BANDS & BUCKLES

- Natural Aluminum .025" x 750" x 100'
- Anodized Aluminum .025" x 750" x 100'
- Stainless Steel .015" or .030"



### BANDING TOOL FOR STAINLESS BANDING - BT-01



### ALUMINUM NAILS - AN-1.5

Designed for safety-reduce accidents

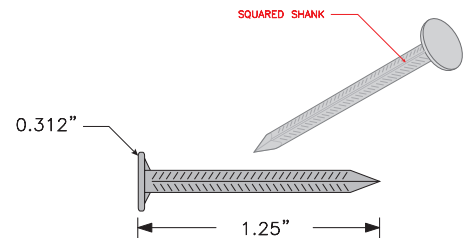

426 Sand Shore Road, Unit 3, Hackettstown, NJ 07840 • [csr@lordoninc.com](mailto:csr@lordoninc.com)

